

## LITHIUM IRON PHOSPHATE (LIFEPO4) BATTERY LP Series



2.56~10.24KWH | WIFI

The LP1600 Series offers a versatile and reliable power solution. Combine up to 15 units for energy capacities ranging from 2560Wh to 10240Wh. With WiFi Remote Monitoring, stay connected and in control. Whether it's wall-mounted convenience, stacked-mounting (up to 5 units) for space efficiency, or rack-mounted for industrial power management, this series offers seamless adaptability.



- ▲ 3-in-1: wall-mounted, rack-mounted, stacked-mounted
- ▲ Large capacity, high power output
- ▲ Safest lithium iron phosphate battery cell with high energy density
- ▲ Modular design: supports up to 15 units in parallel
- ▲ IP21 protection for both indoor use
- ▲ Support CAN & RS485 communication with mainstream inverters
- ▲ Local monitoring via LCD monitor
- ▲ Built-in WiFi Smart BMS Module

### Back panel description

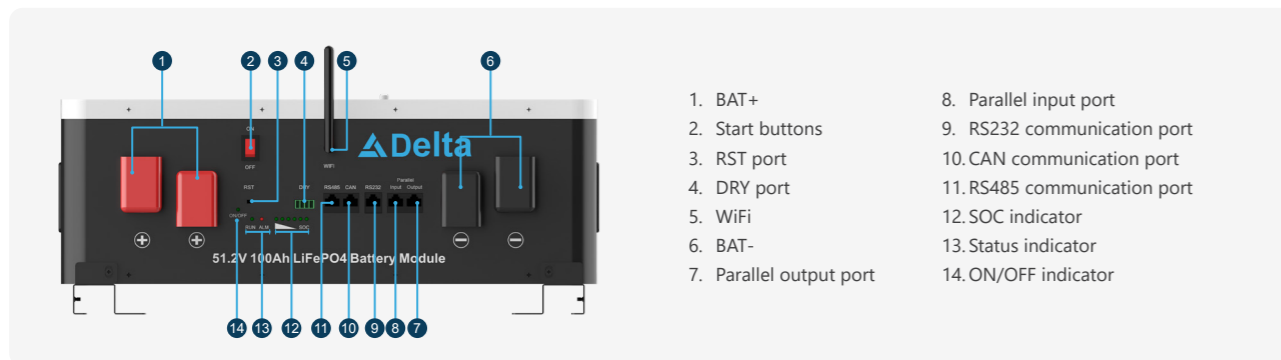

### Installation method



Technical Data		LP24100	LP24200	LP48100	LP48200
Nominal Voltage		25.6V		51.2V	
Nominal Capacity		100Ah	200Ah	100Ah	200Ah
Nominal energy		2560Wh	5120Wh	5120Wh	10240Wh
Life Cycles		8000 Cycles @ 60% DOD, 25°C			
Recommended Charge Voltage		29.2V		58.4V	
Recommended Charge Current		20A	40A	20A	40A
End Of Discharge Voltage		22V		44V	
Standard Method	Charge	20A	40A	20A	40A
	Discharge	50A	100A	50A	100A
Maximum Continuous Current	Charge	100A	150A	100A	150A
	Discharge	100A	150A	100A	150A
BMS Cut-Off Voltage	Charge	29.2 V (3.65V/Cell)		58.4 V (3.65V/Cell)	
	Discharge	22.0V (2s) (2.75V/Cell)		44.0V (2.75V/Cell)	
Temperature	Charge	0 ~ 45°C			
	Discharge	-10 ~ 55°C			
Storage Temperature		-5~35°C			
Shipment voltage		≥25.6V		≥51.2V	
Module Parallel		Up to 15 units			
Communication		CAN2.0/RS232/RS485			
Case Material		SPPC			
Machine Dimension (H*W*D) (mm)		485.5*442*177	486.5*442*250	625.5*442*177	686.5*442*250
Package Dimension (W*H*D) (mm)	carton box	557*547*227	557*547*300	688*557*227	non
	wooden box	555*565*340	555*565*410	696*565*335	759*569*391
N.W (kg)		27	44	45	80
G.W (kg)	carton box	30	48	48	non
	wooden box	40	57	58	97

\* Variations in dimensions and weights may occur due to production batches.

Charge Retention And Capacity Recovery Capability: Standard charge the battery, and then put aside at room temperature for 28d or 55°C for 7d, Charge retention rate≥90%, Recovery rate of charge≥90

Certification & Standards: CE-EMC (EN 61000-6-3: 2007+A1: 2011+AC: 2012 EN IEC 61000-6-1: 2019) IEC62619-1:2018; IEC62619:2022; IEC62619:2017; UN38.3/ MSDS